

Häny Mixing and Injection Technology

High Shear Mixer HCM 600



The colloidal mixer is particularly suitable for the production of suspensions consisting of water, cement, ultra-fine binder, bentonite, sand, and other materials. A robust mixing tank combined with highly wear-resistant materials in the mixing pump guarantee a long service life and trouble-free operation.

HÄNY

Mixing and Injection Technology

High Shear Mixer

HCM 600

Key features

- ▶ Excellent mixing results thanks to the high turbulence generated by the high-speed mixing pump
- ▶ Mixing tank with conical bottom and recirculation line
- ▶ Automatic lubrication of the shaft seal and lubricated 3-way valve for switching between mixing or transfer
- ▶ Optional additional mixer for water/cement ratio < 0.5 and microcements

Typical applications

- ▶ Preparation of suspensions consisting of water, cement, ultra-fine binder, bentonite, sand, and other materials
- ▶ As a stand-alone system or in combination with agitator and injection pump

3D model



High shear mixer

Mixing pump:	TMP 22
Approx. capacity ¹ :	8 m ³ /h
Circulation capacity:	1,400 l/min
Usable content:	550 l
Max. aggregate size:	8 mm
Liquid temperature:	Max. 40°C
Water connection:	BSP 1½"

Optional

- Water meter 1½" for exact water dosing (manual shut-off)
- Automatic water meter 1½" with adjustable counter for exact water dosing
- Auxiliary mixing unit 3x 400/460 V, 50/60 Hz (3.0/3.6 kW)

¹: Water to cement ratio = 1



Electrical data

Voltage:	3x 400/460 V
Frequency:	50 / 60 Hz
Nominal power:	9.2 / 10.5 kW
Nominal current:	16.8 / 17.6 A
Speed:	1,465 / 1,765 min ⁻¹

Weight and dimensions

Approx. weight:	370 kg
Width:	1,025 mm
Height:	1,750 mm
Length:	1,360 mm

Design and dimensions

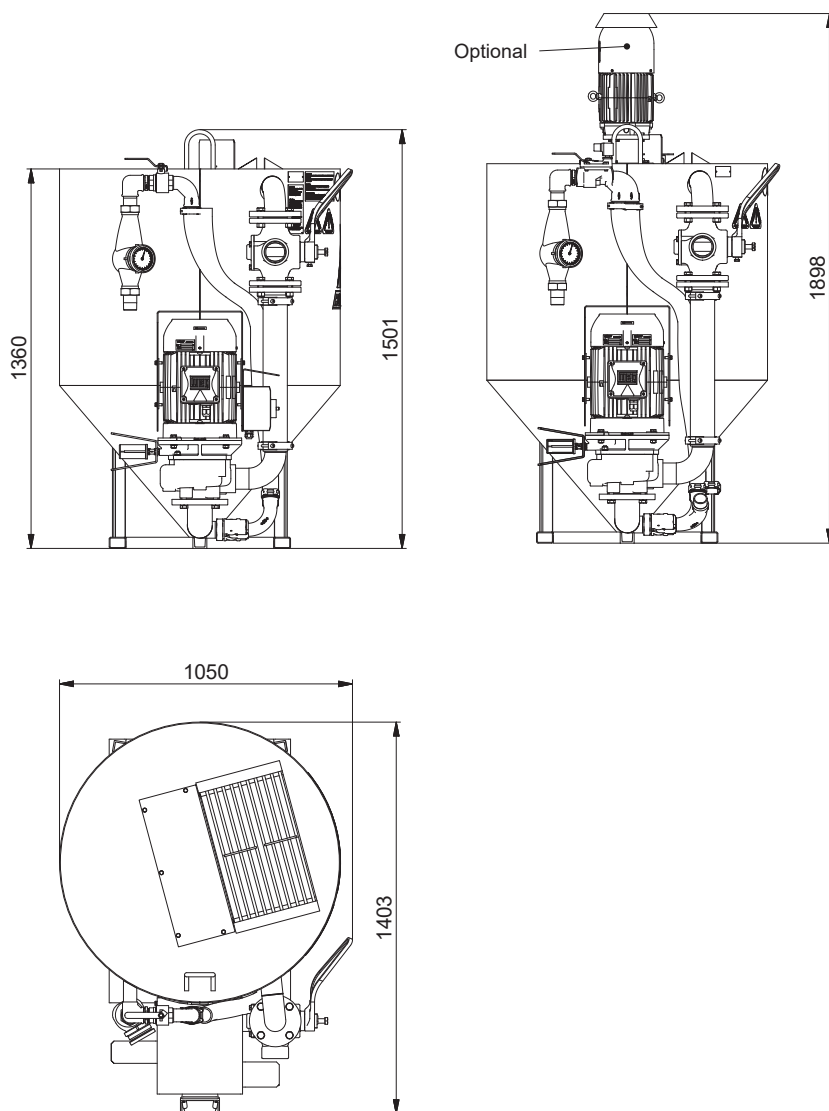

Document No. PW2-102072-00/10; 18. Legal Notice © Copyright 2018, Häny AG, Jona/Switzerland. Any unauthorized use or copying of the contents or any part hereof is prohibited. Illustrations and photos may show equipment with optional extras. No warranty is made regarding specifications or otherwise. Specifications and equipment are subject to change without notice.



HÄNY
Mixing and Injection Technology

Häny AG – Mixing and Injection Technology
Buechstr. 20 | 8645 Jona/Switzerland | Phone +41 44 925 41 11 | www.haeny.com