

Häny Mixing and Injection Technology

Agitator HRW 1200

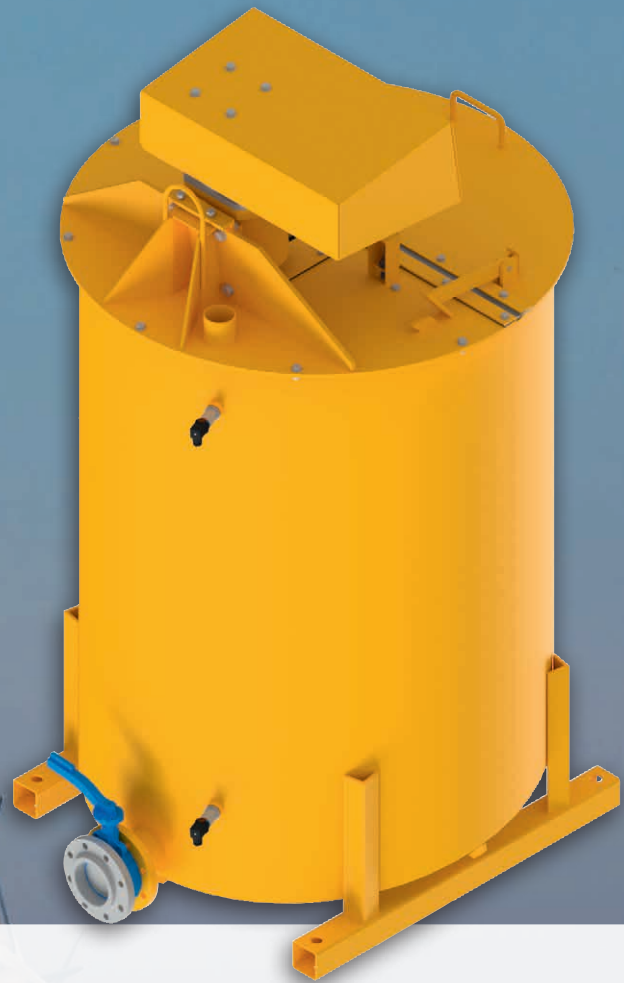

Agitators ensure continuous operation by holding and homogenizing the mixed suspension and removing any air bubbles by means of a slowly rotating paddle. Optional level sensors enable fully automatic operation.

HÄNY

Mixing and Injection Technology

Agitator

HRW 1200

Key features

- ▶ Complete circulation of the tank contents by means of an agitator shaft arranged angled to the tank with mixing paddle (no hard-to-clean static paddles)
- ▶ Slowly rotating paddle for homogenization of the mixed material and removal of existing air bubbles
- ▶ Cleaning opening with safety switch
- ▶ Central hitching point for easy transportation
- ▶ Level sensors for fully automatic operation

Typical applications

- ▶ Holding tank between mixer and injection pump

3D model



Agitator

| | |
|---------------------|-----------|
| Usable content: | 1050 l |
| Liquid temperature: | Max. 40°C |
| Inlet connection: | 2½" |
| Outlet connection: | 2" |

Optional

- Level sensors 1", "full - empty"
- Flange connection with butterfly valve 2½"



Electrical data

| | |
|----------------|---------------------------|
| Voltage: | 3x 400/460 |
| Frequency: | 50 / 60 Hz |
| Nominal power: | 1.5 / 1.8 kW |
| Speed: | 34 / 40 min ⁻¹ |

Weight and dimensions

| | |
|-----------------|----------|
| Approx. weight: | 450 kg |
| Width: | 1,343 mm |
| Height: | 2,216 mm |
| Length: | 1,198 mm |

Design and dimensions

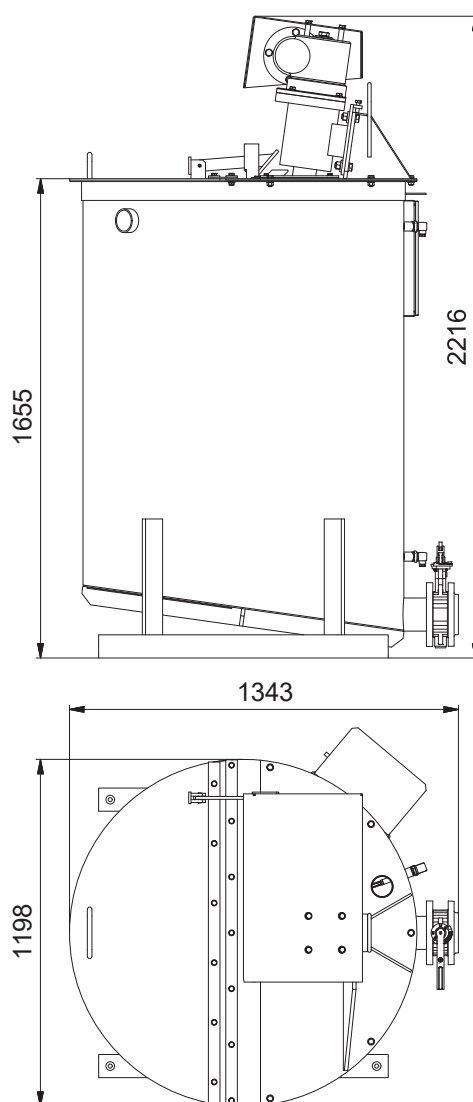

Document No.: PM2-102060-00/10; 18. Legal Notice © Copyright 2018, Häny AG, Jona/Switzerland. Any unauthorized use or copying of the contents or any part hereof is prohibited. Illustrations and photos may show equipment with optional extras. No warranty is made regarding specifications or otherwise. Specifications and equipment are subject to change without notice.



HÄNY
Mixing and Injection Technology

Häny AG – Mixing and Injection Technology
Buechstr. 20 | 8645 Jona/Switzerland | Phone +41 44 925 41 11 | www.haeny.com