

HÄNY-ECOLINE



High-performance pumps for urban drainage and sewage transport



Häny AG

pumps, turbines and systems
Buechstrasse 20
CH-8645 Jona
Switzerland

Phone +41 44 925 41 11

info@haeny.com

www.haeny.com

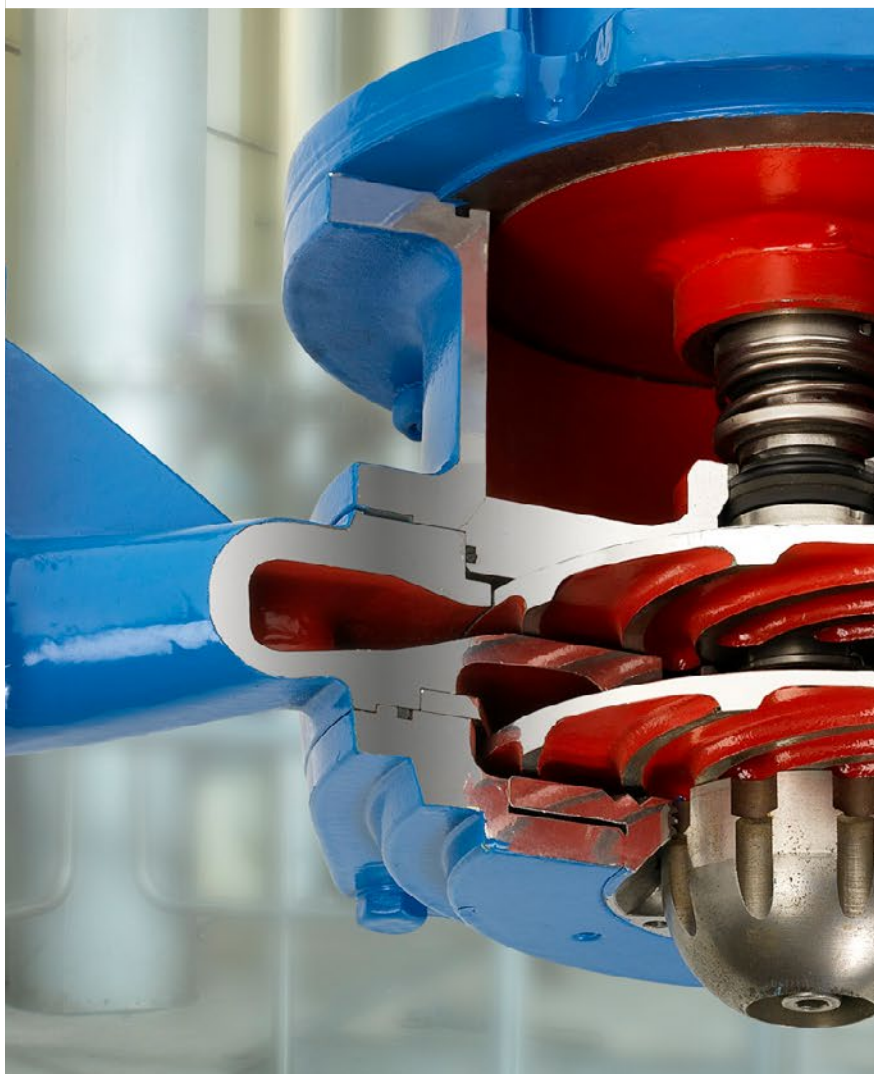



HÄNY- ECOLINE

PRODUCT RANGE

Häny-Ecoline 4

ECOCUT®

Model 2405 | 1-stage 6

Model 2406 | 2-stage 8

Model 2406/2405 | in series 10

ECONEX®

Model 2402 12

ECOCUT® ECONEX®

Sewage pressure drainage systems 14

YOUR ADVANTAGES

with Häny pumps 16

ECOVOX®

Model 2404 WW 18

Model 2403 DR 20

ATEX-Motors

Model BG 90 | 100 | 132 22

HÄNY AG

Services 24

About us 26

PRODUCT RANGE

Häny-Ecoline

High-pressure drainage

Pressure drainage systems in urban water management permit the connection of individual properties and parts of villages to a distant channel system. Our pumps, equipped with a unique cutting system made of hardened special steel, can overcome

extremely long pipe distances with delivery pressures **up to 16 bar**. By using these products together with small pipe cross-sections, the total cost of the drainage system can be significantly reduced.

Product line for grinder pumps



- With 1 and 2-stage centrifugal hydraulics
- Maximum pressure: 8 bar (16 bar as a series installation)
- Flange connection for coupling to any third-party system
- Hydraulic unit that is easily adjustable from outside



- Progressive cavity hydraulic grinder pump
- Maximum pressure: 12 bar (installed with only 1,8 kW at 0,6 l/s flow rate)
- Transmission with hermetically encapsulated cardan joint



Low-pressure drainage

The sturdy Vortex series Ecovox®, a clog-free hydraulic drainage and wastewater pump, is suitable to transport both sewage containing faeces and without faeces. The proven Vortex impellers guarantee high hydraulic efficiency.

A special flange connection is used for coupling to any third-party system. Häny pumps are used either as a sewage lifting unit in buildings or in various process stages in the sewage plant.

Product line for sewage/drainage pumps



- The classic sewage pump DN80 with Vortex impeller moves any problematic media charged with solids
- Fibre-repellent system to protect the mechanical seal



- The classic drainage pump DN50 with Vortex impeller moves any media slightly charged with solids

All high-pressure and low-pressure pumps are characterised as follows:

- ATEX as standard
- Motor with a high efficiency class, although not required by the standards
- Two mechanical seals connected in series in oil bath
- SIC/SIC mechanical seal on the medium side
- Heavy-duty double row bearing as a fixed bearing on the hydraulic side
- Three Klixon connected in series for temperature monitoring
- Leakage detection in specially designed chamber
- Motor hydraulic connection with service-friendly v-band
- Special heat dissipation system for high running times without water on the motor

Our production site is also certified to:

- ISO 9001/14001
- ATEX 2014/34/EU, VII

In addition to the usual checks, the pumps are subjected to a full:

- motor test: no-load current and insulation measurement and
- hydraulics test: operating point measurement with water.

ECOCUT®

Model 2405 | 1-stage

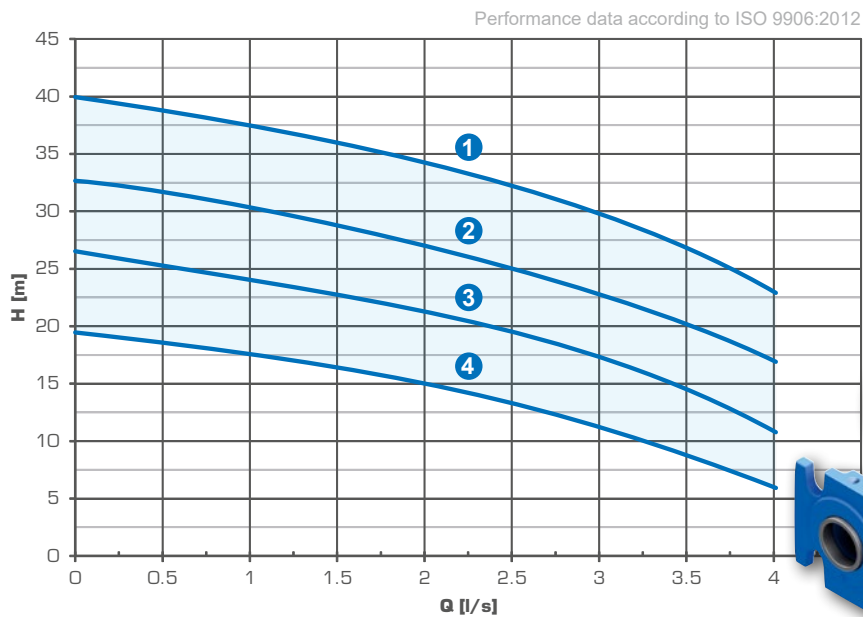

High-quality design in gray cast iron, with a grinding unit of hardened special steel for sewage and faeces. Its field of use is in sewage disposal for individual properties and parts of villages. The blockage-free, integrated

grinding unit ensures that the pumping medium can be transported through a De40 line. Straight lengths of line (De50) of **up to 700 m** can be overcome. These pumps come in the standard design ATEX.

Curve No.	Part No.	DND "	Nominal performance P2 kW	Impeller Ø mm	Tension V	Weight kg
1	2405-KY-99	1½	3.0	175	3x400	61
2	2405-KY-98	1½	2.7	165	3x400	61
3	2405-KY-97	1½	2.2	150	3x400	60
3	2405-KY-96	1½	2.2	150	3x230	60
4	2405-KY-95	1½	1.5	133	3x400	59
4	2405-KY-94	1½	1.5	133	3x230	59



Technical data

Medium:..... Faecal sewage without rainwater
Discharge connection:..... DN 40
Speed, n:..... 2900 min⁻¹
Frequency, F:..... 50 Hz
Equivalent free passage:..... 5 mm
Protection class:..... IP 68
Insulation class:..... F
Performance cable:..... NSSHÖU, 1 x (7 x 1.5 mm²)
Cable length:..... 10 m
Mode of operation:..... S1/S3
Explosion protection:..... II 2G Ex c d IIB T4 Gb

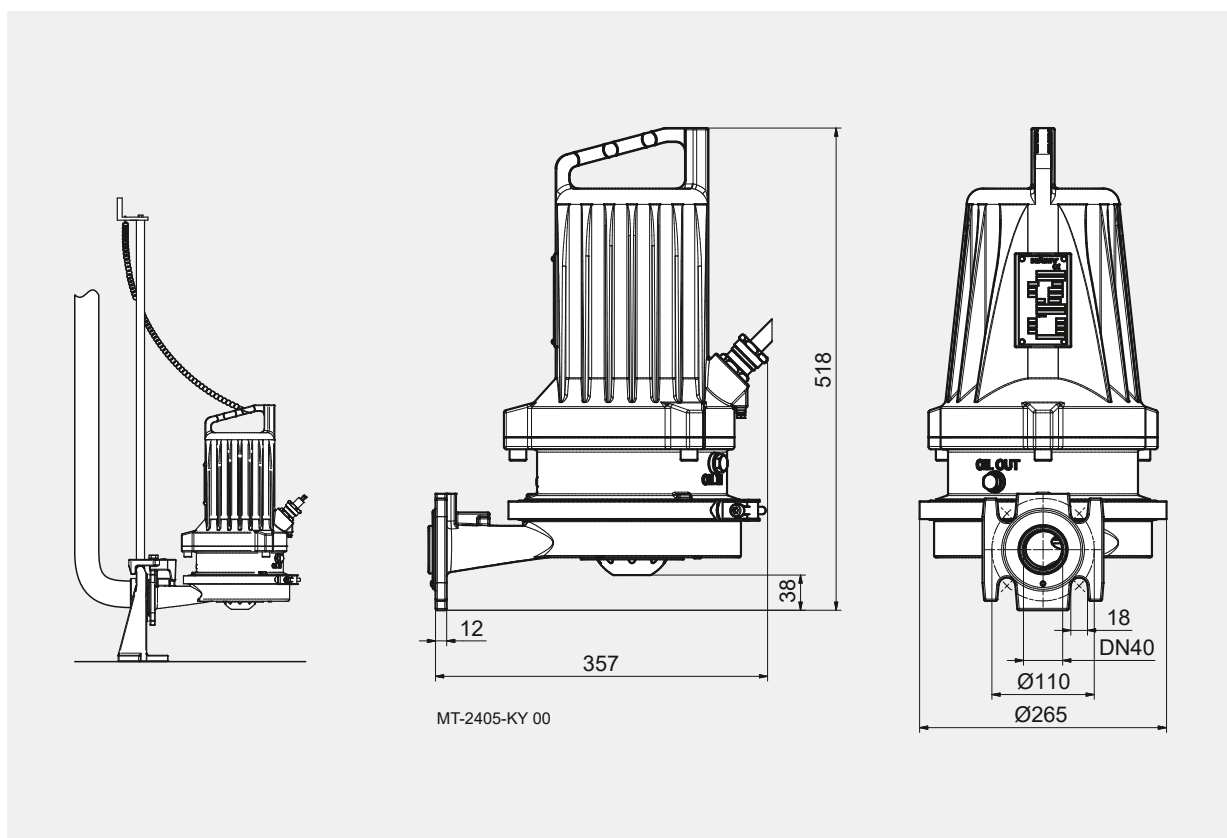

Delivery conditions: see page 26

ECOCUT®

Model 2406 | 2-stage

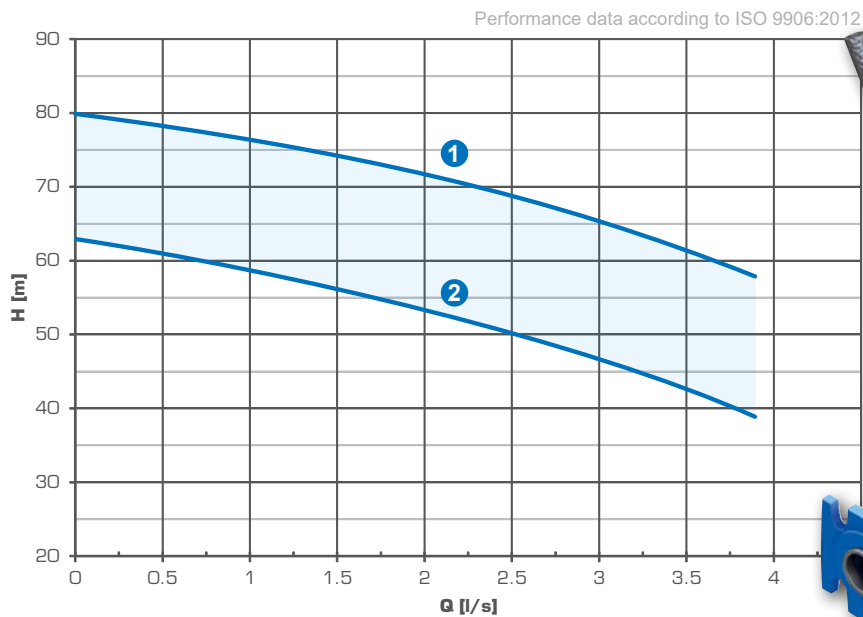

High-quality design in gray cast iron, with a grinding unit of hardened special steel for sewage and faeces. Its field of use is in sewage disposal for individual properties and parts of villages. The blockage-free, integrated

grinding unit ensures that the pumping medium can be transported through a De40 line. Straight lengths of line (De50) of **up to 1400 m** can be overcome. These pumps come in the standard design ATEX.

Curve No.	Part No.	DND "	Nominal performance P2 kW	Impeller Ø mm	Tension V	Weight kg
1	2406-KY-99	1½	8.0	180	3x400	130
2	2406-KY-98	1½	6.5	163	3x400	127



Technical data

Medium:..... Faecal sewage without rainwater
Discharge connection:..... DN 40
Speed, n:..... 2900 min⁻¹
Frequency, F:..... 50 Hz
Equivalent free passage:..... 5 mm
Protection class:..... IP 68
Insulation class:..... H
Performance cable:..... NSSHÖU, 1 x (10 x 2.5 mm²)
Cable length:..... 10 m
Mode of operation:..... S1/S3
Explosion protection:..... II 2G Ex c db IIB T4 Gb

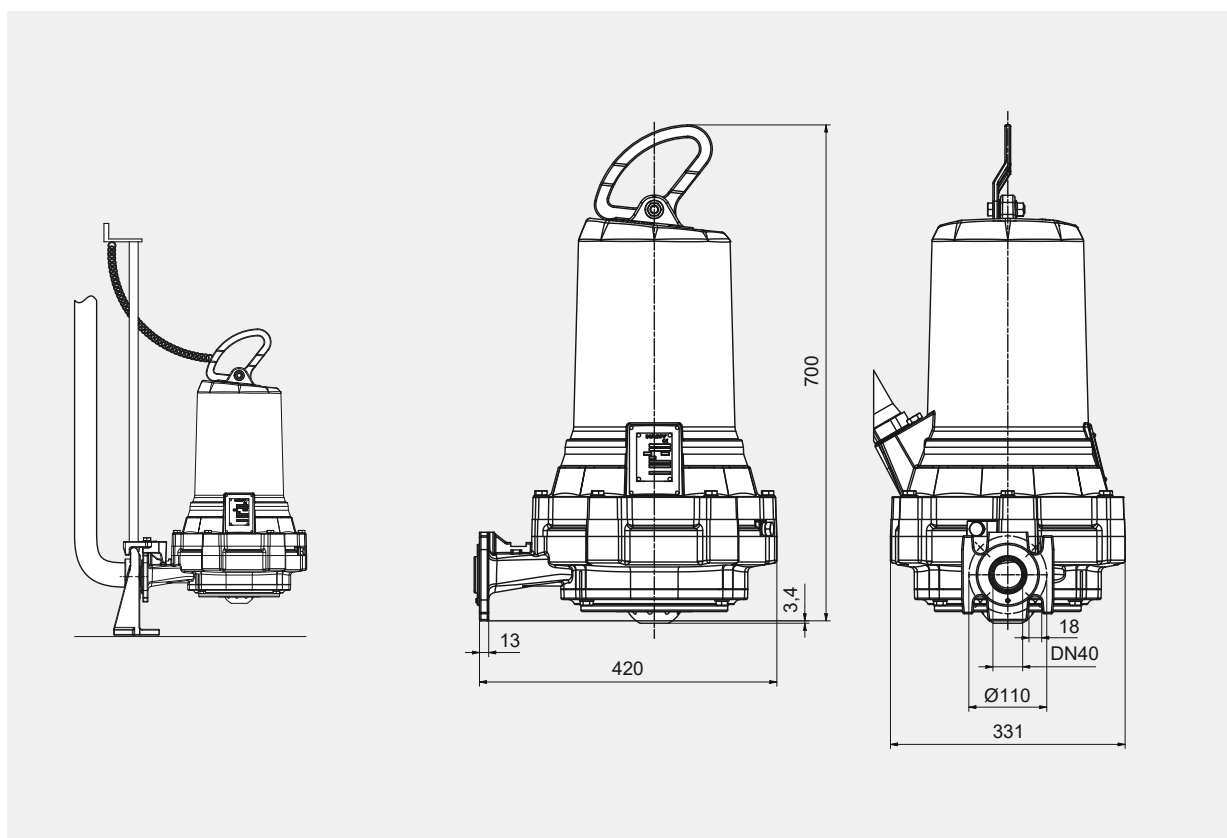

Delivery conditions: see page 26

ECOCUT®

Model 2406/2405 | in series

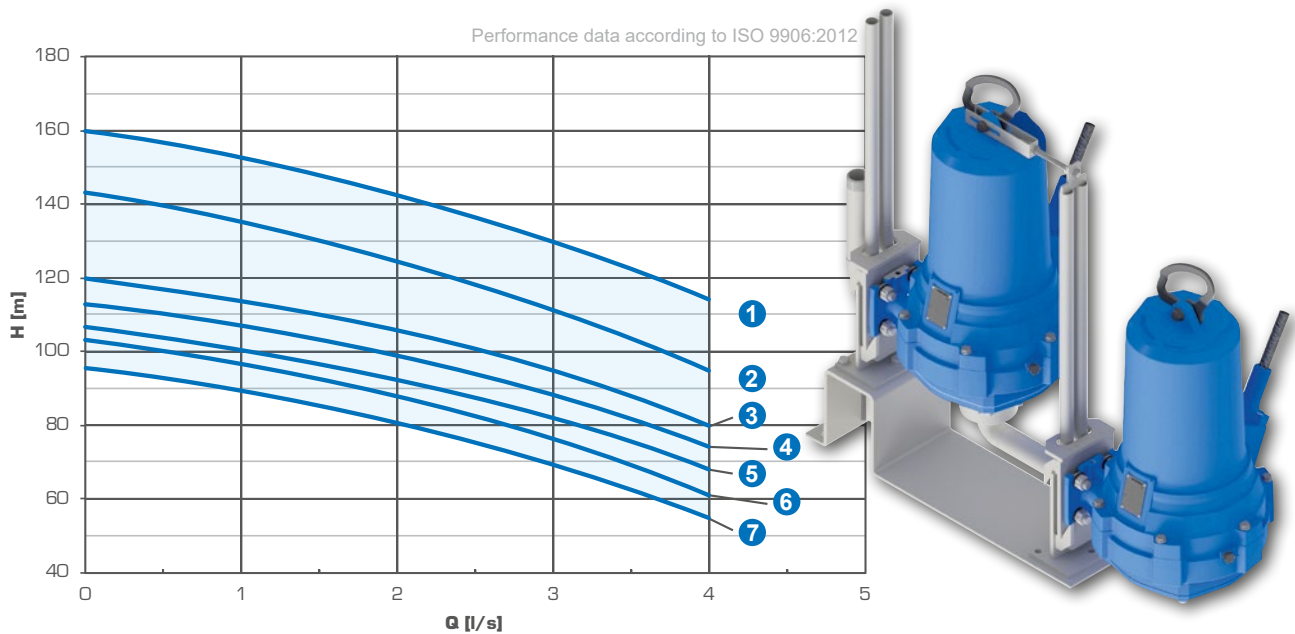

With a combination of the 2406 and 2405 units in series the 80 meter limit can be increased to a **maximum of 150 meter** head and all required operating duties can be achieved. Thanks to this combination pipelines of up to **3000 meters** long (De50) can be pumped.

This makes even those places that are normally out of reach, possible to connect to the public sewer system. This also achieves **large cost savings** for this type of pump station. These pumps come in the standard design ATEX.

Curve No.	Part No.	DND "	Nominal performance P2 kW	Impeller Ø mm	Tension V	Weight kg
1	2406-KY-89 + 2406-KY-99	1½	8.0 + 8.0	180 + 180	3x400	260
2	2406-KY-89 + 2406-KY-98	1½	8.0 + 6.5	180 + 163	3x400	257
3	2406-KY-89 + 2405-KY-99	1½	8.0 + 3.0	180 + 175	3x400	191
4	2406-KY-89 + 2405-KY-98	1½	8.0 + 2.7	180 + 165	3x400	191
5	2406-KY-89 + 2405-KY-97	1½	8.0 + 2.2	180 + 150	3x400	190
6	2406-KY-88 + 2405-KY-99	1½	6.5 + 3.0	163 + 175	3x400	187
7	2406-KY-88 + 2405-KY-98	1½	6.5 + 2.7	163 + 165	3x400	187



Technical data

Medium:..... Faecal sewage without rainwater
Discharge connection:..... DN 40
Speed, n:..... 2900 min⁻¹
Frequency, F:..... 50 Hz
Equivalent free passage:..... 5 mm
Protection class:..... IP 68
Cable length:..... 10 m

Model 2406:
Insulation class:..... H
Performance cable:..... NSSHÖU, 1 x (10 x 2.5 mm²)
Explosion protection:..... II 2G Ex c db IIB T4 Gb

Model 2405:
Insulation class:..... F
Performance cable:..... NSSHÖU, 1 x (7 x 1.5 mm²)
Explosion protection:..... II 2G Ex c d IIB T4 Gb

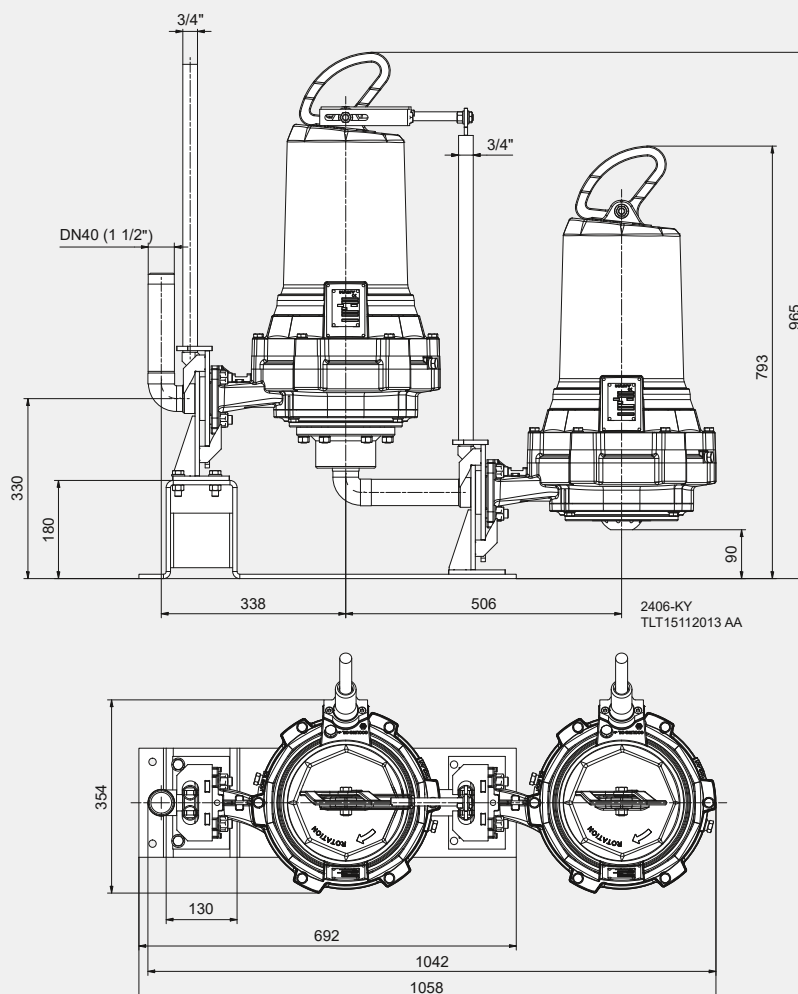

Delivery conditions: see page 26

ECONEX®

Model 2402

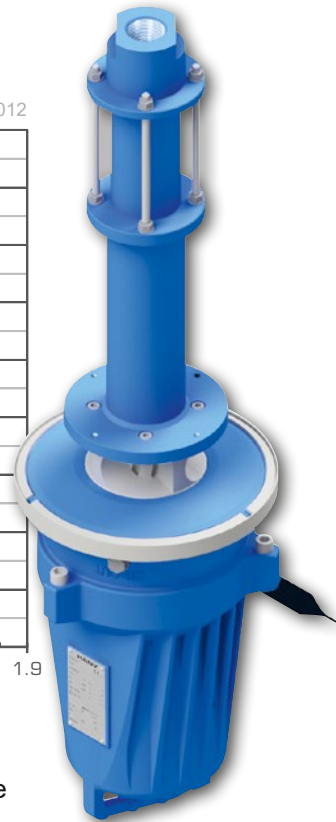
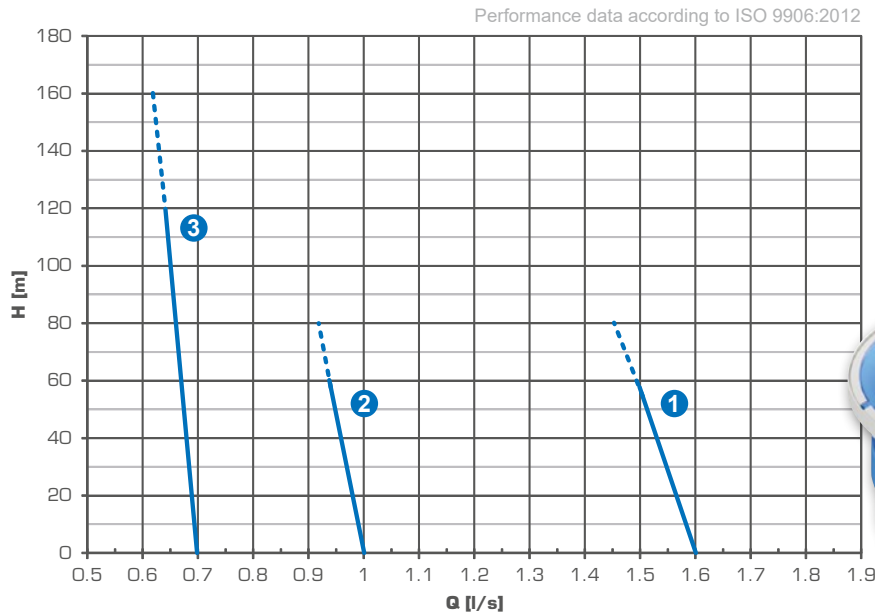

The 2402 is a unique positive-displacement, submersible motor-driven pump with grinding unit of hardened special steel for sewage and faeces. Its field of use is in sewage disposal for individual properties and parts of villages. The blockage-free, integrated grinding unit ensures

that the pumping medium can be transported through a De32 line. Straight lengths of line (De40) of **up to 4500 m** can be overcome. These pumps come in the standard design ATEX. They can be installed either horizontally or vertically.

Curve No.	Part No.	DND "	Nominal performance P2 kW	Speed min ⁻¹	Hydraulic	Tension V	Weight kg
1	2402-KY-99	1¼	2.5	1450	BIG-1S	3x400	68
1	2402-KY-98	1¼	2.5	1450	BIG-1S	3x230	68
2	2402-KY-97	1¼	1.5	950	BIG-1S	3x400	65
2	2402-KY-96	1¼	1.5	950	BIG-1S	3x230	65
3	2402-KY-95	1¼	1.8	1450	SMALL-2S	3x400	65
3	2402-KY-94	1¼	1.8	1450	SMALL-2S	3x230	65



Technical data

Medium:..... Faecal sewage without rainwater
Discharge connection:..... 1¼"
Frequency, F:..... 50 Hz
Equivalent free passage:..... 5/8 mm
Protection class:..... IP 68
Insulation class:..... F
Performance cable:..... NSSHÖU, 1 x (7 x 1.5 mm²)
Cable length:..... 10 m
Mode of operation:..... S1/S3
Explosion protection:..... II 2G Ex c d IIB T4 Gb

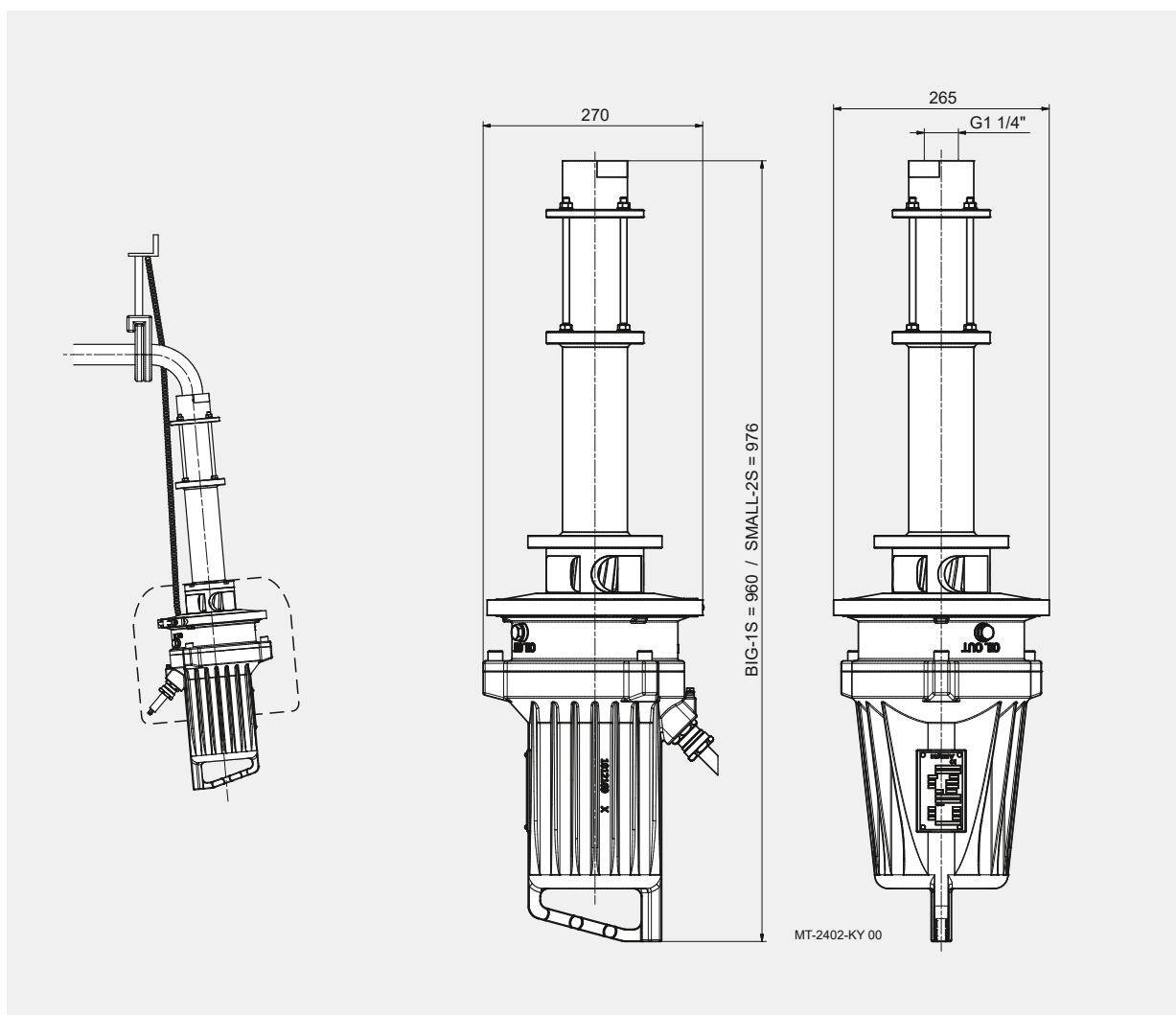

Delivery conditions: see page 26

ECOCUT® ECONEX®

Sewage pressure drainage systems

A typical application for sewage pressure drainage systems is the connection to properties outside the municipal sewage network. The typical requirement would be to transport a small quantity (0.55 - 4 l/s) over a longer distance of up to 4500 meters.

Conventional sewage pumps operate with an increasing pressure and flow in an area with a low pump efficiency and therefore a high energy consumption. As in this case long piping distances have to be covered, the friction loss over this distance increases the head the pump has to overcome and therefore also

total energy costs. Häny Ecocut® and Econex® pumps have been designed specially for this type of application, and bring a failure free operation with lowest possible operating costs.

A conventional sewage pumping station is usually equipped with a delivery pipeline of 80 mm diameter. With a Häny Ecocut® and Econex® pumping station the incoming solids are cut with the grinding mechanism that reduces the size of the solids, so that the main pipeline inside diameter can be reduced to 40/32 mm. This in turn reduces the purchase price of the installation and the

laying of the main pipeline. The machinery used needs only to cut a narrow trench or in some cases the piping can even be fed straight into the ground, with a vibratory plough. In this way even difficult terrain can be overcome.

The line routing must be taken into account with very long line lengths. In order to prevent hydraulic shocks and air pockets and to allow a run off in the line, bleed/vent valves are used and/or the delivery volume is regulated with a frequency converter.

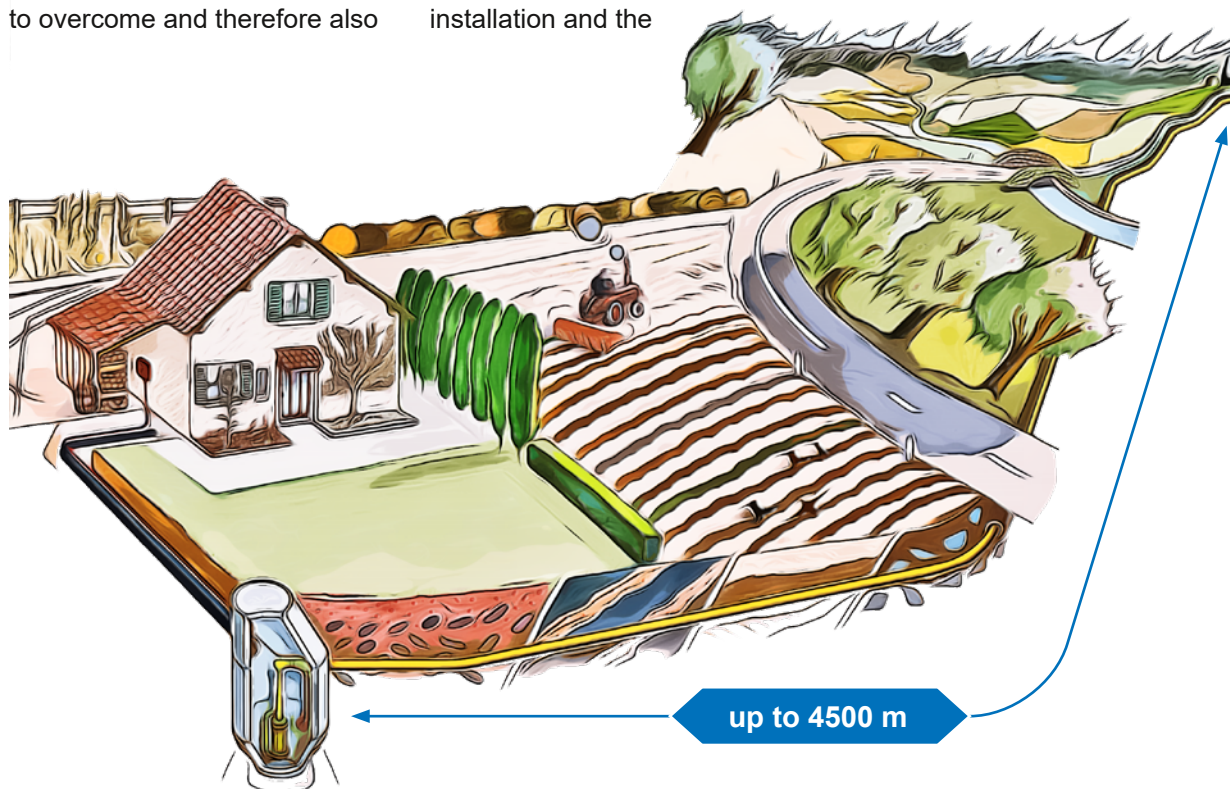



Häny Ecocut[®] and Econex[®] pumping stations are today available in Single or Parallel operation.

Why a Parallel pumping installation?

1. To reach a larger total flow capacity.
2. With the failure of one pump it is still possible to transport a large part of the Sewage with the second pump.
3. With the increase of the flow input the second pump can be started, which will insure that in critical situations the flow output can be increased.
4. An automatic pump change with the pump control, insures that all pumps are always ready for operation.

Great care must be taken to ensure that the system is serviced regularly so as to guarantee trouble-free operation over a longer period of time.

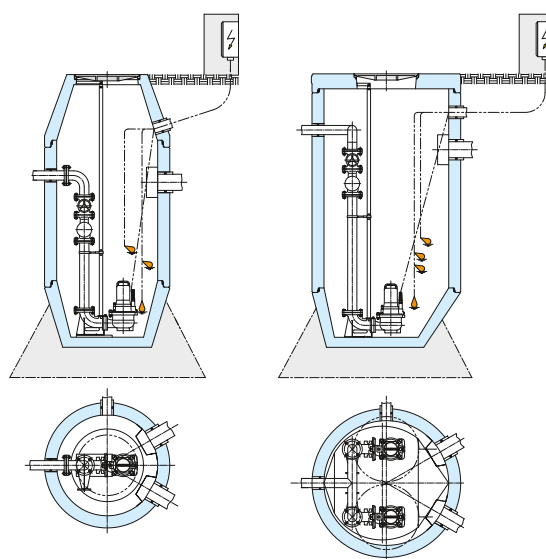

Single pump system

Parallel pump system

YOUR ADVANTAGES

with Häny pumps

The following calculation shows that the Häny Ecocut[®] or Econex[®] station saves you up to 20 - 45 % in costs, in comparison to a similar quality conventional sewage pump station.

Sewage system with conventional sewage pumps

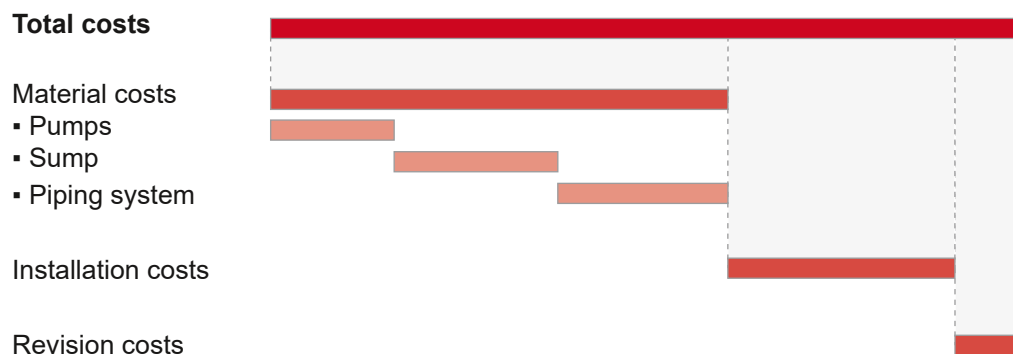
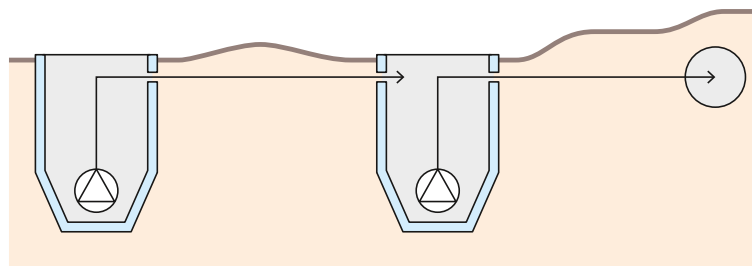



Sewage system with Häny Ecocut® or Econex® pumps

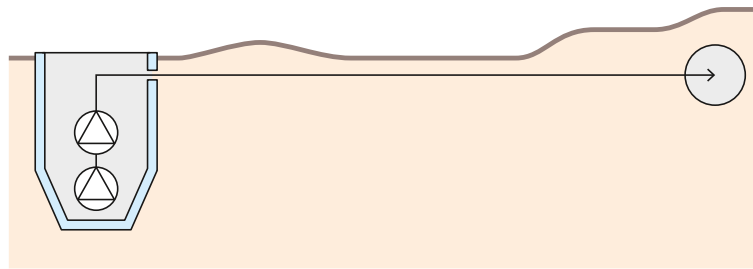

Total costs

Material costs

- Pumps
- Sump
- Piping system

Installation costs

Revision costs

Cost saving

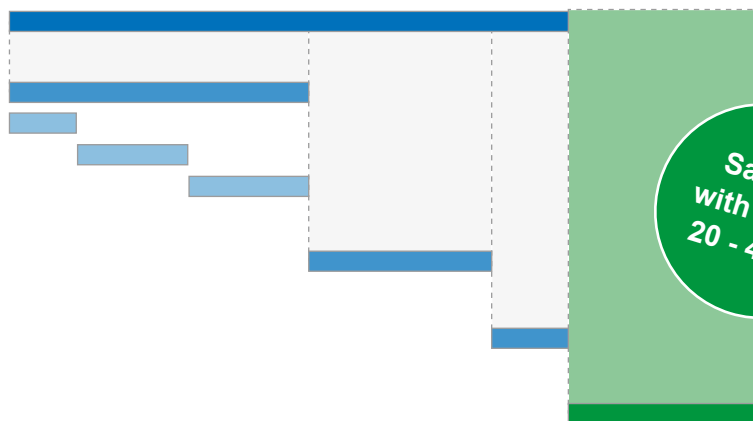

**Saving
with Häny
20 - 45 %**

Our dealers in your area would be pleased to calculate for you the benefit you derive from our Ecocut® and Econex® pumps.

ECOVOX®

Model 2404 WW

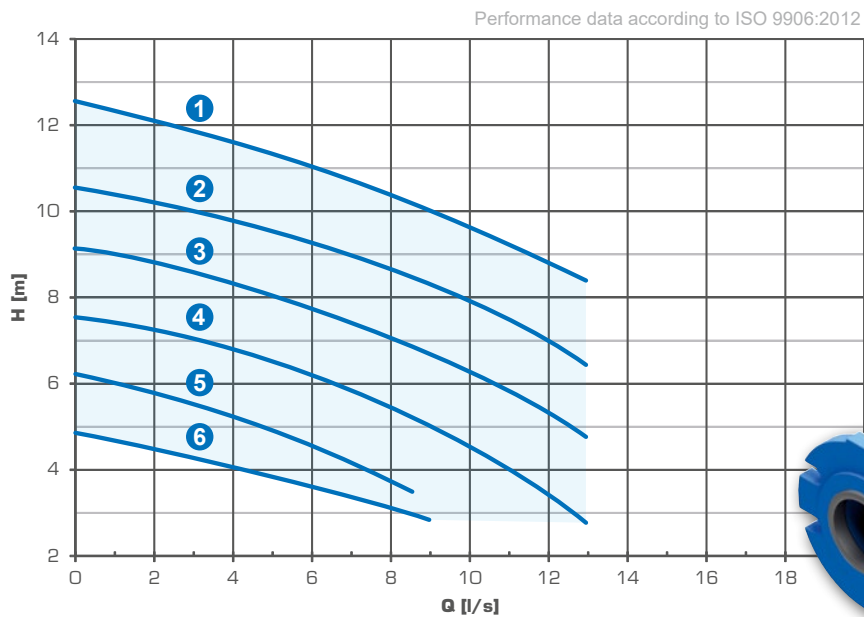

High-quality design in gray cast iron. Suitable for transporting effluent, faecal sewage and sewage with various solid shares. Has a blockage-free, sturdy Vortex impeller hydraulics with a large free passage. The pumps are

used either as sewage lifting units in buildings or in various process stages in sewage plants. Each pump is tested individually on the hydraulic test bench in the manufacturer's works.

Curve No.	Part No.	DND	Nominal performance P2 kW	Speed min ⁻¹	Impeller Ø mm	Tension V	Weight kg
1	2404-KY-99	80	2.7	1450	220	3x400	71
2	2404-KY-98	80	2.2	1450	205	3x400	69
2	2404-KY-97	80	2.2	1450	205	3x230	69
3	2404-KY-96	80	1.9	1450	190	3x400	69
3	2404-KY-95	80	1.9	1450	190	3x230	69
4	2404-KY-94	80	1.5	1450	175	3x400	68
4	2404-KY-93	80	1.5	1450	175	3x230	68
5	2404-KY-92	80	1.5	1450	160	3x400	66
5	2404-KY-91	80	1.5	1450	160	3x230	66
6	2404-KY-90	80	1.1	950	220	3x400	66
6	2404-KY-89	80	1.1	950	220	3x230	66



Technical data

Medium:.....	Effluent and faecal sewage
Discharge connection:.....	DN 80
Frequency, F:.....	50 Hz
Equivalent free passage:.....	80 mm
Protection class:.....	IP 68
Insulation class:.....	F
Performance cable:.....	NSSHÖU, 1 x (7 x 1.5 mm ²)
Cable length:.....	10 m
Mode of operation:.....	S1/S3
Explosion protection:.....	II 2G Ex c d IIB T4 Gb

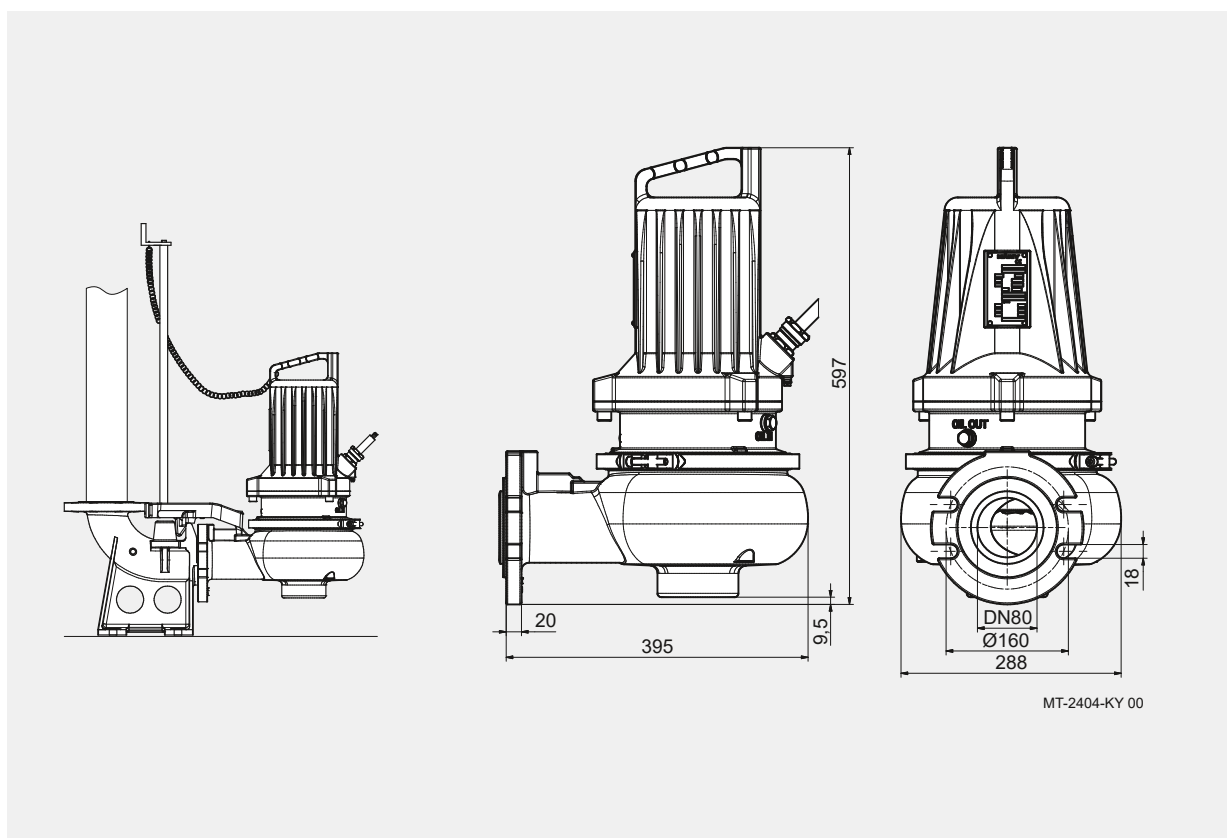

Delivery conditions: see page 26

ECOVOX®

Model 2403 DR

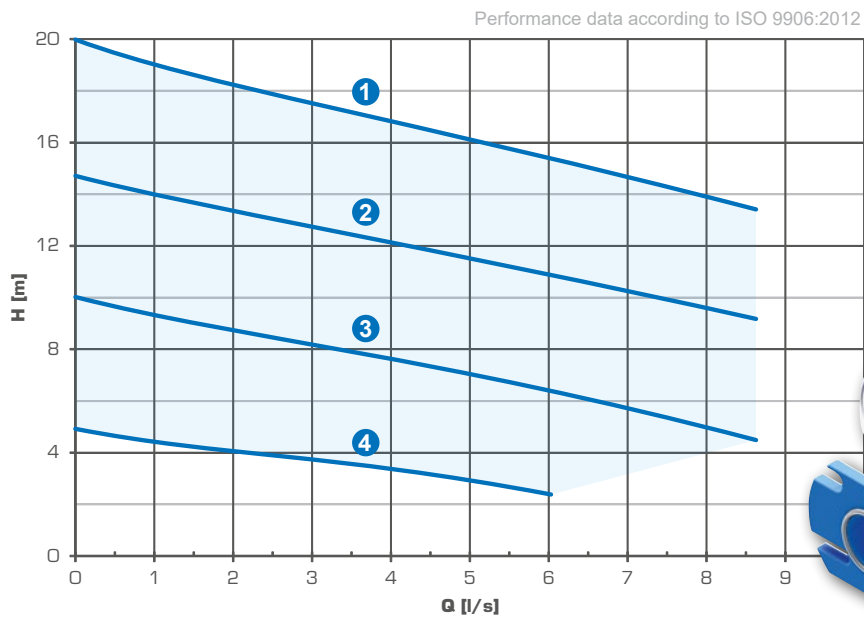

High-quality design in gray cast iron. Thanks to the sturdy Vortex impeller hydraulics, the pump is suitable for transporting all kinds of effluent and, within limits, for faecal sewage. The pumps are used in

residential construction, trade and in industry. The pump comes with a deep well or on feet on request. Each pump is tested individually on the hydraulic test bench in the manufacturer's works.

Curve No.	Part No.	DND	Nominal performance P2 kW	Speed min ⁻¹	Impeller Ø mm	Tension V	Weight kg
1	2403-KY-99	50	3.0	2900	120	3x400	59
2	2403-KY-98	50	2.2	2900	100	3x400	58
2	2403-KY-97	50	2.2	2900	100	3x230	58
3	2403-KY-96	50	1.5	2900	85	3x400	57
3	2403-KY-95	50	1.5	2900	85	3x230	57
4	2403-KY-94	50	0.6	1450	120	3x400	56
4	2403-KY-93	50	0.6	1450	120	3x230	56



Technical data

Medium:..... Effluent, within limits with faeces
Discharge connection:..... DN 50
Frequency, F:..... 50 Hz
Equivalent free passage:..... 40 mm
Protection class:..... IP 68
Insulation class:..... F
Performance cable: NSSHÖU, 1 x (7 x 1.5 mm²)
Cable length: 10 m
Mode of operation:..... S1/S3
Explosion protection: II 2G Ex c d IIB T4 Gb

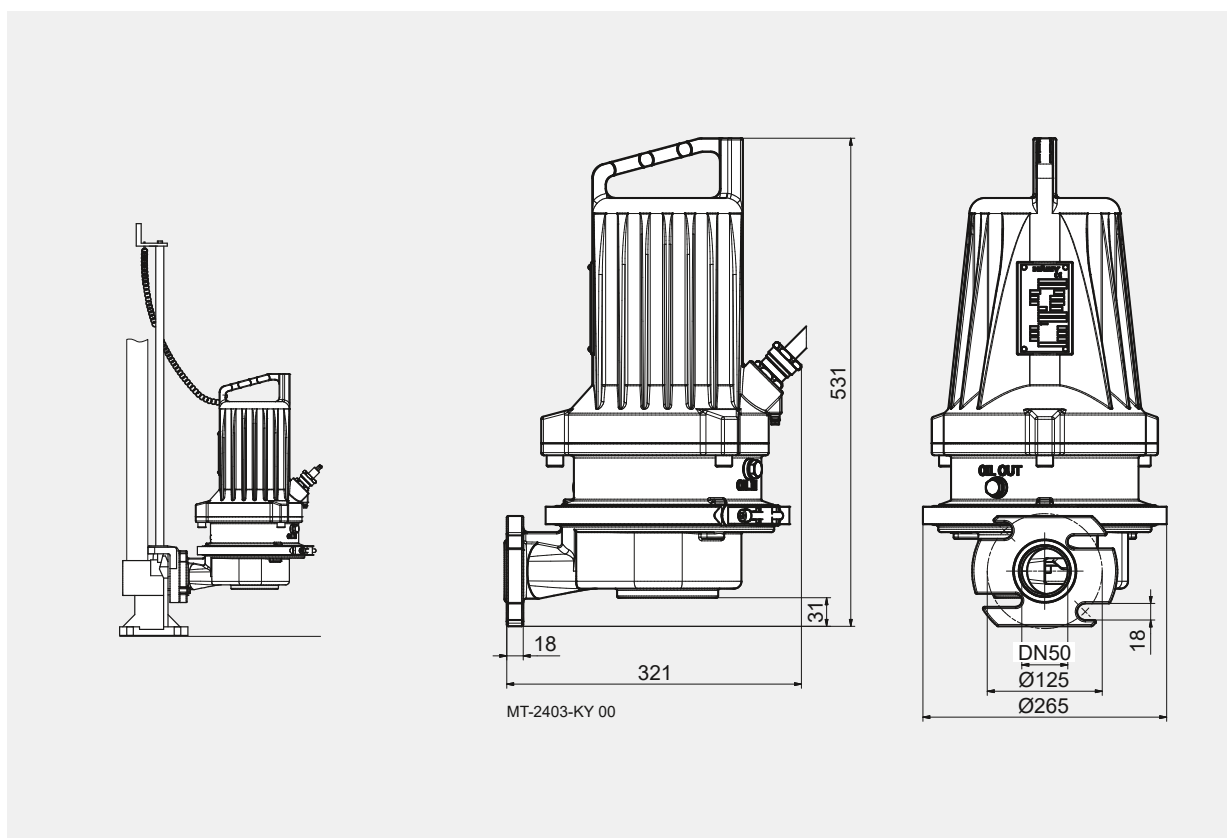

Delivery conditions: see page 26

ATEX-Motors

Model BG 90 | 100 | 132

The special motor concept is based on an identical flange/shaft connection for each type of pump that allows their cost-efficient production despite the numerous quality features.

- ATEX als Standardausführung
- Motor with a high efficiency class, although not required by the standards
- Two mechanical seals connected in series in oil bath
- SIC/SIC mechanical seal on the medium side
- Heavy-duty double row bearing as a fixed bearing on the hydraulic side
- Three Klixon connected in series for temperature monitoring
- Motor hydraulic connection with service-friendly v-band
- Special heat dissipation system for high running times without water on the motor
- Each motor is tested individually on the electrical test bench in the manufacturer's works

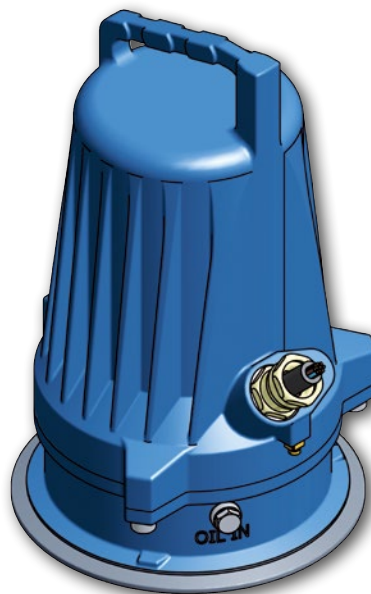

Technical data

BG90/100

Nominal performance, P2:.....0.6 - 3 kW
Speed, n:950/1450/2900 min⁻¹
Insulation class: F
Tension, U:.....230/400 V

BG132

Nominal performance, P2:.....6.5 - 8 kW
Speed, n:2900 min⁻¹
Insulation class:H
Tension, U:.....400 V

Frequency, F:.....50 Hz
Protection class: IP 68
Performance cable: 10 m
Mode of operation:..... S1/S3



Model BG90 | BG100

for Econex 2402, Ecovox 2403, 2404
and Ecocut 2405

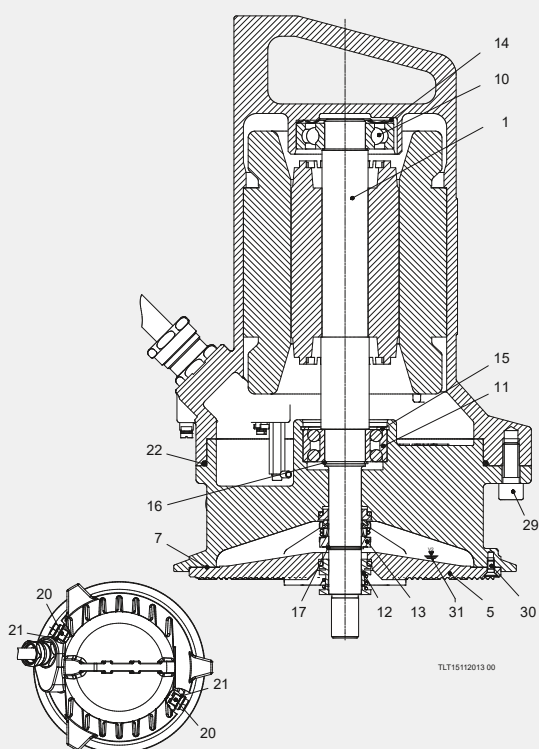

No. Description

1	Rotor
5	Intermediate cover
7	Flat seal
10	1Groove ball bearing
11	Angular ball bearing, two rows
12	Mechanical seal BQ1P
13	Mechanical seal Q1Q1
14	Spring washer
15	Lock ring
16	Lock ring
17	Lock ring
20	Drain plug
21	Fibre-sealing ring
22	O ring
29	Cylinder screw In-6kt ISO 4762-M 12x30-A4-70
30	Countersunk screw In-6kt ISO 10642-M5x12-A4-70
31	Oil

Oil quantity: ca. 1.6 liter
Oil type: PANOLIN TRAF0 C1
SHELL DIALA OIL B

Model BG132

for Ecocut 2406

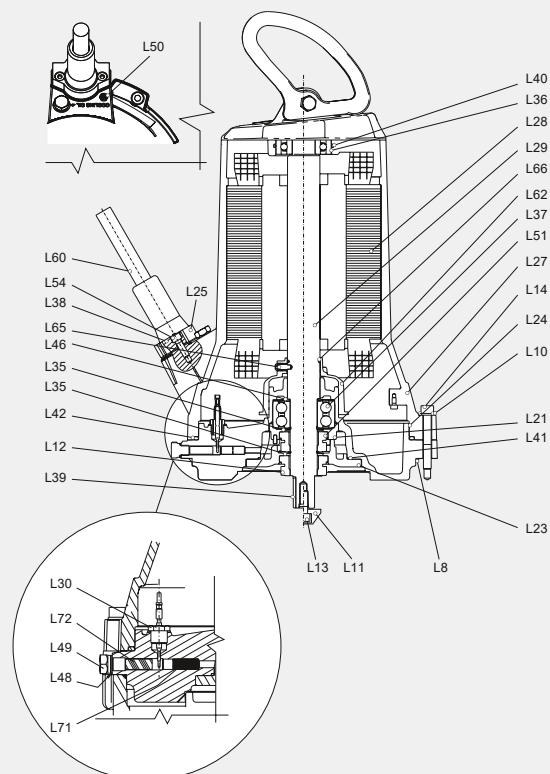

No. Description

L8	OR ring
L10	Elastic washer
L11	Washer
L12	Mechanical seal on pump side
L13	Screw
L14	Screw
L21	Bearing housing
L23	Bearing flange
L24	Oil chamber
L25	Cable gland
L27	Motor casing
L28	Stator
L29	Shaft with rotor
L30	Conductivity detector Plug (X Version)
L35	Spring ring
L36	Bearing
L37	Bearing
L38	Seal
L39	Key
L40	OR ring
L41	OR ring
L42	OR ring
L46	Washer
L48	Washer
L49	Plug
L50	Ground screw
L51	Mechanical seal on motor side
L54	Screw
L60	Complete round power supply cable
L62	Oil centrifuge
L65	Grub screw
L66	O ring
L71	Flame arrester
L72	Membrane

Oil quantity: ca. 0.18 liter
Oil type: ISO 32 - SAE 10W, ARNICA 32 - Agip,
DTE 24 - Mobil, NUTO H32 - Esso,
TELLUS S 37 - Shell, PANOLIN TRAF0 C1
or analog

HÄNY AG

Services

Häny AG offers other products and services for export.

Complete overhauls

Häny AG specialises in the complete overhaul of Sulzer pumps manufactured before 1999 in Winterthur (CH), particularly the HPL, HPH, BPK and BPS series.

After a complete overhaul, the pump is technically and hydraulically "as new". The efficiency is at least equivalent to that at its initial acquisition.

Thanks to the earlier takeover of the "Sulzer Pumpen Schweiz (PUCH)" business unit we were able to preserve and further develop the valuable know-how.





Energy production (Made in Switzerland)

Energy production from drinking water is very important for water supplies that are of ecological and economic interest. Häny AG has been successfully involved in this field for several years. The systems can usually be installed in existing supply structures with no problems. Häny can offer the following product lines in this sector:

Back-pressure Pelton turbines

A proprietary development that can be operated in closed systems and thus has the big advantage that they can be installed in existing structures with no modifications. Power range 1 - 2000 kW.

- with European drinking water certification
- in a vertical design, 1 to 3 jets

Pelton turbines

Our assortment covers the power range from 1 kW to 2000 kW.

- with European drinking water certification
- in a vertical and horizontal design, 1 to 3 jets



HÄNY AG

About us

Our aim is not to meet your expectations, but to surpass them – and to enthuse you.

Innovative and safe pump solutions, turbine and injection systems

For decades, Häny AG has been a household name for pump and system technology for water supply and sanitation in the municipal and industrial segments. Our know-how also leads to convincing and clear results in building services engineering as well as swimming pool technology. Offering innovative turbine solutions, Häny AG enables more efficient use of renewable water power in times of energy shortages. Last but not least, we are among the leading manufacturers of injection systems.

Top quality over 6 generations

Ever since its foundation by Eduard Häny-Pfister in 1875, Häny AG has been a family business. Today the company is managed by the sixth generation of the family and employs roughly 170 staff. Over time, the

company has transformed itself from a pump manufacturer into a systems provider. For the most part procuring our pumps from the global market, we are now capable of suggesting to our customers the best possible solution in specific situations. Where unusually sophisticated pumps or special solutions are called for, we continue to manufacture these in Jona, Switzerland.

Your competent services and solution

By thinking and acting outside the box and thanks to our unique consultancy, manufacturing and servicing competence, we are able to offer the optimal solution for any product range. All from one source – reliable, custom-tailored, and safe.

Warranty

For machines and systems: 24 months, at maximum 30 months from delivery ex works or report that product is ready for shipping, in any other case according to the most recent version of the «General terms and conditions for machines and systems» by SWISSMEM.

For revisions and spare parts: 12 months, at maximum 18 months from delivery ex works or report that product is ready for shipping, in any other case according to the most recent version of the «General terms and conditions for machines and spare parts» by SWISSMEM.

SWISSMEM terms and conditions of delivery represent an integral part of this document. The following has been explicitly excluded from warranty:

1. Costs incurred from the direct use of a component subject to warranty (transport and travelling expenses, accommodation, disassembly and assembly costs as well as any other third-party costs),
2. Wear parts, such as shaft seals and cutting systems (list is not exhaustive).



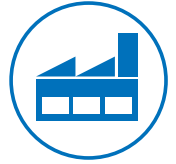

Headquarters Häny AG Jona, Switzerland

Sales partners:

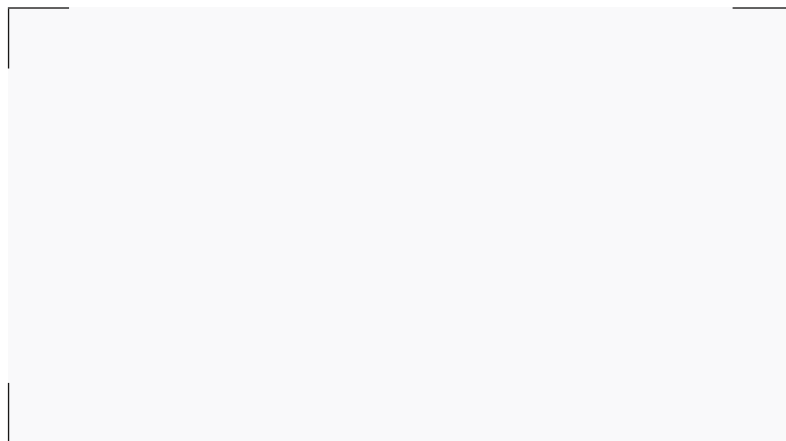

Subject to changes

PM2-101256 06 / 12.2021 / ecoline



Häny AG - pumps, turbines and systems Häny SA - pompes, turbines et systèmes Häny SA - pompe, turbine e sistemi
Buechstrasse 20 • CH-8645 Jona • Tel. +41 44 925 41 11 • Fax +41 44 923 38 44 • info@haeny.com • www.haeny.com